

---

THE ASME  
CODES &  
STANDARDS  
WRITING  
GUIDE

---

*2000*

---

**THE ASME  
CODES &  
STANDARDS  
WRITING  
GUIDE**

---

*2000*



The American Society of  
Mechanical Engineers

ASME is the registered trademark of The American Society of Mechanical Engineers.

No part of this document may be reproduced in any form,  
in an electronic retrieval system or otherwise,  
without the prior written permission of the publisher.

The American Society of Mechanical Engineers  
Three Park Avenue, New York, NY 10016-5990

Copyright © 2000 by  
THE AMERICAN SOCIETY OF MECHANICAL ENGINEERS  
All Rights Reserved  
Printed in U.S.A.

# FOREWORD

As technology continues to quickly advance, it is becoming increasingly evident that there is a need to provide clear and concise information. Tools such as the Internet provide people with the ability to gather enormous amounts of data. The challenge, therefore, is to be able to provide structure and meaning for the data. As an organization devoted to the advancement of codes and standards, the ASME's continuing goal is to make technology a true servant of all people. As an organization that is a proponent of the development of consensus documents, it is vital to be able to pave the path for the commonality of presentation of certain data.

*The ASME Codes & Standards Writing Guide 2000* has been totally revised and new material added to provide an overview to a common writing platform for ASME Codes and Standards publications, and technical publications in general. We hope that you will find the guide to be of value and service, as well as a helpful manual for technical writing. *The ASME Codes & Standards Writing Guide 2000* is by no means a definitive work, but we hope that this tool is of use to all, from the general public to the technical and scholarly writer.

ASME Codes and Standards Publishing's primary goal is to offer these guidelines for organization and content management. ASME must be able to work with its global members and consensus committees in establishing protocols from which to operate. We do hope that *The ASME Codes & Standards Writing Guide 2000* fulfills this goal.

This page intentionally left blank.

# CONTENTS

<b>Foreword</b> .....	iii
<b>Style</b> .....	1
<b>Format</b> .....	13
<b>Special Policies</b> .....	21
<b>Examples</b>	
1 Title Page .....	29
2 Copyright Page .....	30
3 Foreword .....	31
4 Committee Correspondence .....	32
5 Contents .....	33
6 Main Text .....	34
7 Tables .....	35
8 In-Text Table .....	36
9 Art .....	36
10 Equations .....	38
11 Mandatory Appendix .....	38
12 Nonmandatory Appendix .....	39
13 Index .....	40
<b>Reference Notations</b>	
List of SI Units .....	43
Abbreviations .....	44
Proofreading/Copyediting Marks .....	45

This page intentionally left blank.

# STYLE

This page intentionally left blank.

# STYLE

In order to maintain consistency of meaning and presentation among ASME Codes and Standards, these publications are edited according to Codes and Standards Publishing's house style. Adhering to established ASME style ensures that similar information is presented in a similar manner in all books, which contributes to better understanding of the material, especially for our international users. Among other editorial concerns, style includes, for example, how things are stated, the order in which information is presented, punctuation, and abbreviations. These and other style matters will be covered in this section.

## PURPOSE/AUDIENCE

Before writing a code or standard, it is helpful to define the purpose of the document. What is the publication intended to convey and to what extent? How is the reader expected to use the code or standard and what action does he/she need to take in regard to the document? What information and what emphasis should be communicated to enable the reader to take the recommended action? Once these issues are considered, a scope should be written for the document. The scope should clearly define what information the code or standard covers. Typically, the scope is the first designated paragraph of the book.

It is important to keep the user of the code or standard in mind at all times. Who is going to reference it, who will take some action because of it, and what background or knowledge does the reader most likely have? How can the code or standard be arranged so that the reader will be sure to understand its meaning? If something is not clearly stated it will not be clearly understood. Also, bear in mind that some international users may be reading English as a second language; therefore, clarity, concision, and proper grammar are important to the expression of the technical information.

## REQUIREMENTS

*Standards:* A standard can be defined as a set of technical definitions and guidelines that function as instructions for designers/manufacturers and operators/users of equipment. Standards can run from a few pages to a few hundred pages, and are written by professionals who serve on ASME committees. Standards are considered voluntary because they are guidelines and are not enforceable by law.

ASME publishes standards, accredits users of standards to ensure that they are capable of manufacturing products that meet those standards, and provides stamps that accredited manufacturers may place on their products to indicate conformance to a standard.

*Codes:* A code is a standard that has been adopted by one or more governmental bodies and is enforceable by law.

*Codes and Standards:* Additionally, to be considered a valid ASME code or standard, a document:

(a) should be suitable for repetitive use. A major requirement of a code or standard is that it can be used time and again. If a set of requirements is so specialized that it cannot and will not be applied repeatedly, it is not a code or standard.

(b) should be enforceable. A standard's requirements should be worded so that a person auditing its use or application can point out where it has been followed or where it has not been followed, or the extent to which it has or has not been followed.

(c) should be definite. Requirements that are too general or that contain vague applications instead of workable instructions are impractical and often useless. Requirements should be expressed as specific instructions and never as explanations.

(d) should be realistic. Requirements should not be arbitrary; rather, they should be based on factors that are necessary to achieve the purpose of the standard. Requirements that are unrelated, excessive, or more restrictive than necessary should not be included. A standard that is too restrictive or too detailed imposes a burden on both the administrator and the user. Increasing the severity or detail of a requirement does not automatically increase quality, but will nearly always increase cost. Be ready to justify, in writing, if necessary, every requirement of the standard, and be able to show the basis of each as a logical deduction from factual information about the item or practice in question.

(e) should be authoritative. Requirements should be technically correct and accurate, and should cover only those properties that are subject to control or that are of legitimate use. Requirements should be reasonably consistent with current practices and capabilities in the industry and be attainable for the user.

(f) should be complete. All areas open to question or interpretation (or misinterpretation) should be covered. If requirements are specified in terms of, or by reference to, another standard, all areas of the referenced standard that are open to question or misinterpretation should also be covered.

(g) should be clear. Express the requirements in simply understood language that is free from ambiguity. Language should be precise and concise. Avoid common pitfalls such as run-on sentences, wordiness, redundancy, and complex sentence structures.

(h) should be consistent. Requirements should not be contradictory or incompatible with one another; similarly, the requirements of related and dependent standards should also be consistent with each other. Also, the requirements should be compatible with the requirements of the documents referenced in the standard, and the standard should reflect national or international standards whenever possible. Special (i.e., nonstandard) sizes, shapes, or tests require special attention and extra time on the part of the user and therefore increase cost; they also inhibit maintenance and repair.

(i) should not cover too broad a scope. When too much is covered by one standard, its requirements become confused and watered-down, and the standard loses its flexibility; users may be left wondering what parts of the standard apply to their work. When the standard applies to a number of users, with different requirements for each, it is often more desirable to provide separate standards.

## **PREPARING TO WRITE AN ASME CODE OR STANDARD**

Create a detailed outline to serve as a guide for collecting and developing material for the code or standard. Make as many subdivisions as possible in the outline; unnecessary ones can be easily omitted later. Be sure that the outline reflects the emphasis you want, and that the divisions and subdivisions bear the proper relationship of equality and subordination to one another. Also, refer to the next section of this Guide for information regarding the format of a document so that all the necessary parts and elements are accounted for in your outline.

Once the parts and elements of the proposed document have been identified, they should be adequately organized with numerical/alphabetical designators and titles or captions. If a paragraph, table, figure, or appendix cannot be readily titled and given a designator, some incongruity or misappropriation probably exists in the outline and consideration should be given to rearrangement. Designation is the most crucial aspect of the document's organization; equal thought and consideration should be given to a document's overall structure and its technical content. As much as possible, most codes and standards should follow similar patterns of arrangement and designation. At the very least, related codes and standards usually follow established parallel structures; this is particularly true within a series.

## RECURRING SECTIONS

As mentioned earlier in this section, typically the scope is the first designated paragraph of the book. The scope is usually simply designated and titled “**1 SCOPE**,” no more than a few paragraphs long, and may or may not include a breakdown [i.e., (a), (b), (c), etc.]. It is a careful, overall description of the code or standard’s purpose and what it covers (and possibly what it does not cover). The scope should adequately define the parameters of a document so that someone who is interested in the subject matter will know from the scope whether the code or standard addresses topics of particular concern to them.

Frequently the scope is followed by a definitions section, simply designated and titled “**2 DEFINITIONS**,” that consists of a brief introductory paragraph followed by an alphabetical (letter by letter) listing of terms, acronyms, abbreviations, symbols, and phrases relative to the document. Capitalization, primarily needed for acronyms, should be otherwise sparingly used. Anything that is listed should have a definition; do not use terms as headings for subterms. Subterms should be alphabetically arranged beneath main definitions in the same manner. Colons are used to separate the terms from the definitions, and all definitions should end with a period.

Often a references section, “**3 REFERENCES**,” follows the definitions section. The bibliographic information should be documents that the reader of the standard can obtain if he/she wishes to consult related publications. Technical papers, out-of-print books, in-house reports, or other documents that might be difficult to obtain should not be listed. Where information used in the creation of the code or standard is available only in such relatively unavailable documents, the portion that pertains to the code or standard should be extracted and included either in the main text or in an appendix. (*See also Use of Copyrighted Material, page 24.*)

The references section should begin with the following statement: “The following is a list of publications referenced in this Code/Standard.” Thereafter, publications should be listed alphabetically and/or numerically by designator, followed by their respective publisher. Publisher information should consist of the organization’s name in full followed by its acronym in parentheses, if applicable, and street and/or mailing address.

A standard, once issued, will be the authority and should not lean on other documents for credibility. References are used as a means of reducing the bulk or detail of the standard. For example, an ASTM publication may be cited for a test method or acceptable material or procedure; however, a paper by an expert in the field should not be cited simply to lend weight to a requirement in the standard.

The preparers/writers of standards should decide whether or not to include the edition year of the referenced document. Consideration should be given to the relationship of the publication being referenced to the standard. If a change in the publication being referenced can affect provisions for safety or interchangeability in the standard, the date of the reference should be cited. In standards where there is little likelihood of such effects, the date may be omitted. Where the date is not included, a statement following the introductory sentence may read: “Unless otherwise specified, the latest edition shall apply.”

*See the Examples section for examples of recurring sections.*

## PRESENTATION

Text, including the recurring sections described above, should be presented using the elements described in the Format section of this Guide. Text should be legible and neatly organized. If an existing code or standard is being revised, be sure that revisions are marked on a page that is the latest version in print, accounting for addenda cycles and errata changes. It is best to have new material typed, double-spaced, and on a separate page when it is a substantial addition or revision to existing text. Paper manuscripts are mandatory and considered the definitive versions of a document.

Information should be visually clear and factually consistent. Equations, figures, and tables should be precise and legible to avoid misinterpretation of data. Also, always introduce a figure or table by referring to it by number (e.g., “Design profiles are shown in Fig. 1.” or “The tolerances are based on the data in Table 5.”) in the main text; these elements should not just appear after or between text without explanation or introduction. Text references to figures and tables in text should be sequential (i.e., introduce Fig. 1 first, then Fig. 2).

Avoid reiteration of a requirement by cross-referencing to the paragraph, table, or figure in which it is first stated (e.g., “Data . . . should be labeled and scaled in units consistent with those in para. 5.5.”). Remember, too, when paragraphs, tables, or figures are deleted or rearranged, cross-references must be rechecked for accuracy.

## KEEPING THE WRITING CLEAR AND CONCISE

The style of writing contributes to the effectiveness and usefulness of a code or standard. It should communicate the same information to all readers. Writing should be concise, clear, and grammatically correct. Syntactical errors and verbosity impede comprehension; therefore, they reduce the standard’s effectiveness. Similarly, terms particular to an industry or technical discipline, undefined acronyms and abbreviations, and overembellishment of language obscure meaning.

Ideally, only one point of information should comprise a sentence, except when directly related or dependent data can be clearly introduced. Ideas should be expressed concisely. Complex sentence structures should be avoided. Similarly, text should be broken into paragraphs as often as possible. (These paragraphs may be undesignated; however, if extensive cross-referencing is planned, frequent designation is preferable.) Passive voice also contributes to verbosity, indirectness, and a lack of authority; use active voice to assert what the person or thing (the subject of the sentence) does or should do.

Codes and standards require the use of technical terms (e.g., permeability, accelerometer, and hydropneumatic) because they are part of the mechanical engineering language. Therefore, it is important to write simply and to use short (or at least familiar) words whenever possible. For instance, *use*, *show*, and *start* can be substituted for *utilize*, *demonstrate*, and *initiate*, respectively.

Excessive wording to express an idea can be limited by avoiding common phrases that do not enhance meaning. Below are examples of wordiness and alternatives for improvement.

Wordy	Better
in the event that	if
in the course of	during
large number/great deal of	many/much (better to specify amounts)
is provided with	has
through the medium of	by
for a duration of	for
in order to/for the purpose of	to

Redundancy may result from a conscious or unconscious effort to emphasize a point. Taking care to use the appropriate words to describe something can lessen the temptation to overstate. Below are examples of redundancies and alternatives for improvement.

Redundant	Better
visible to the eye	visible
aluminum metal	aluminum
physical size	size
fuse together	fuse

## Description

Adjectives and adverbs can enhance meaning and offer more specific description when necessary. However, overmodification (e.g., metric break mandrel open end blind rivets) can lead to confusion, especially when multiple modifiers are not coherently ordered and hyphenated (“open-end blind rivets for break mandrels, metric series” clarifies the subject above and alleviates misinterpretation about breaking open mandrels). Sometimes hyphens are simply needed for compound modifiers: “corrosion-resistant surface,” but, “the surface shall be corrosion resistant.” In addition, qualifying words that are not specific enough lead to ambiguity. For example, what is meant by a “suitable method of test” if there are no requirements that define what is suitable? The writer(s) should ensure that all modifiers are meaningful.

## Synonyms, Acronyms, Abbreviations, and Numbers

Synonyms, particularly synonyms of technical terms, should be used with care. An item should not be called a “particle counter” one time, “the counter” a second, and “the instrument” a third. Even though restating the same term may become repetitive, it reduces the risk of confusion on the part of the reader. Conversely, the same term should never be used for more than one item, even if the context seems to clearly differentiate meaning.

Acronyms should not be invented for the sake of having them, particularly if they are not widely applicable, used, or accepted. Standard acronyms may be used as long as the entire term appears with the first usage. It is also helpful to include the acronym(s) in the “Definitions” section of the code or standard if there is one. After it has been defined, the acronym should be used consistently.

Generally, abbreviations should not be used in text. Words should be spelled out at all times in text (e.g., inside diameter, minimum, manufacturer), with the exception of units of measure when accompanied by a quantity [e.g., 7 in. (but several inches apart), 45 deg angle, 100 mL]. In figures, table captions and column heads, and nomenclature, certain words are or may be abbreviated to conserve space. Abbreviations commonly used in ASME codes and standards are listed at the back of this book.

Numerals should be used in text except when the number is the first word of a sentence or is of a quantity less than 10, including fractions, in which cases the number should be spelled out. Numerals should always be used with units of measure (e.g., 25 mm). A number should never be spelled out and then followed by the numeral in parentheses.

## Similar Words

*Shall and Must:* It is ASME practice to use the word “shall” to express a mandatory requirement of the code or standard (e.g., “...each trolley hoist shall have an identification marking...”). Do not construct requirements by using “must” or “is to be” in the statement.

*Should and May:* Use of the word “should” indicates that a statement is a recommendation, the advisability of which depends on the facts in each situation (e.g., “A warning device should be provided for installations...”). “Should” is always used instead of “may,” since the latter implies that a recommendation is entirely at the reader’s option.

*Which and That:* Often “which” is mistakenly used when “that” is grammatically correct. Many people think that “which” is more formal and, therefore, preferable. In fact, it is actually correct to use “that” when the clause is restrictive (i.e., when there is a specific and definite antecedent as in: “...the tank shall be filled with water to a level that is equivalent to the design load...”). When the clause is unrestrictive and provides supplemental information to the main statement of the sentence (and is often preceded by a comma), “which” is correct (e.g., “...when the design temperature exceeds 150°F, additional design considerations, which are not included in this Standard, are the responsibility of the tank designer.”).

*Assure, Ensure, and Insure:* While similar, the words “assure,” “ensure,” and “insure” have subtle differences in meaning. In ASME standards, “ensure” is preferred and appropriate when the meaning “take steps to see that” or “make sure” is intended (e.g., “Materials and fabrication shall be inspected as necessary to ensure compliance with this Standard.”). “Insure” should be reserved for use when financial matters of insurance are described, and “assure” should be used mainly in the context of quality assurance.

*And/Or:* When stating requirements, avoid using “and/or” because this construction leaves the reader to interpret what is required. Statements should be reworded to clarify intent: instead of “elbows and/or tees,” write “either elbows or tees, or both.”

## General Style Points to Remember

While considering the clarity of the writing, remember to pay close attention to spelling and punctuation. If words are misspelled or writing is misspelled or not punctuated at all, misinterpretation of the information may occur. Additionally, it is important to do the following when writing a code or standard:

(a) use serial commas for lists of three or more items in a sentence (semicolons if even one of the items contains a comma within it);

(b) spell out fractions and whole numbers less than ten, except when they precede a unit of measure;

(c) italicize variables (commonly in equations, nomenclature, figures, and tables, though sometimes also appearing in plain text);

(d) set off parenthetical information using this order of distinction: parentheses, then brackets enclosing parentheses, then braces enclosing brackets, e.g.,  $\{a[b + c(d - e)]\}$  and [7 in. (but several inches apart), 45 deg angle, 100 mL];

(e) abbreviate only in figures and tables, except for units of measure, which should always be abbreviated when following a numerical quantity (*see* the abbreviations list at the back of this book);

(f) capitalize sparingly (pronouns, acronyms) and judiciously; capitalize the first letter of prepositions and conjunctions four letters and longer in titles, and keep units of measure lowercase in all-capital titles and in figure and table captions if they are normally that way; and

(g) generally close words with prefixes (e.g., anti, bi, co, inter, mid, multi, non, over, post, pre, pro, re, semi, sub, super, trans, un, under) and do not hyphenate unless the prefix is standing alone (e.g., over- and underestimation can lead to...), causes a repetition of vowels (e.g., semi-isolated), is combined with a capitalized word or numerals (e.g., non-ASME, mid-1900s), or could be confusing when read (e.g., co-edition).

## FIGURES AND TABLES

Give careful thought to what material, if any, can be presented as figures or in tabular form. Figures should be illustrative of information that is provided in the text, with callouts that include dimensions, descriptions, or other relevant information. Well-conceived and organized tables can provide a lot of data efficiently; however, if only a line or two of data is being presented, creating a numbered table complete with caption and several column heads may be excessive. In these cases, an in-text table may be more appropriate. In-text tables are single-column width, without captions, and contain only a few lines of data.

## EDITORIAL REVIEW

Once a draft has been completed, or even while it is being created, it may be submitted to Codes and Standards Publishing for a preliminary editorial review. This may be particularly helpful in the case of new books or drastically revised ones, and can save time later on if inconsistencies or other editorial discrepancies are discovered at the early stages of the document. Editorial review is not required; however, if questions arise during the process of writing or revising a code or

standard, Codes and Standards Publishing may be consulted for answers and/or suggestions.

## **THE STANDARDIZATION OF CODES AND STANDARDS**

A primary goal of Codes and Standards Publishing is to publish documents that are stylistically consistent and uniformly organized and presented across committees and series. While this is not always possible, it can be achieved to a great extent if everyone involved in the publishing process contributes to the effort. By providing manuscripts that follow the parameters provided in this and the other sections of *The ASME Codes & Standards Writing Guide 2000*, and by not requesting special exceptions (to the style or organization of a document) unique to one committee's preferences, committee members and technical staff help maintain a high editorial standard that gives users confidence in the informational integrity of ASME's publications.

# FORMAT

This page intentionally left blank.

# FORMAT

Standards should be organized into the elements below. A detailed description of each element is given in the Description/Definition of Elements section that follows.

- (a) Title Page
- (b) Foreword
- (c) Contents
- (d) Main Text
  - (1) Chapters/Sections/Subsections
  - (2) Paragraphs/Subparagraphs/Breakdowns
  - (3) Footnotes
  - (4) Notes
- (e) Tables/In-Text Tables
- (f) Art
- (g) Equations
- (h) Appendices
- (i) Index

## DESCRIPTION/DEFINITION OF ELEMENTS

### **Title Page**

The title page contains the designation, edition year, and title of the standard. The edition year is the year in which ANSI approval was granted; for documents not approved by ANSI, the ASME approval year should be used. Until ANSI approval is received, all title pages should be stamped “Tentative, Subject to Revision or Withdrawal.” Codes and Standards Policies CSP-9(a) and (b) contain requirements for title pages on drafts. As a rule, the title page is prepared by ASME staff. *See* Example 1.

### **Foreword**

The Foreword traces the history of a document through its acceptance as an American National Standard, if applicable. Technical information does not appear

in the Foreword. All acknowledgments and background material to the establishment of the document may be presented. The following elements usually appear in a Foreword:

- (a) a history of the standard;
- (b) a description of its purpose;
- (c) for a revision, a description of the principal changes between the current and earlier/previous edition;
- (d) ANSI or ASME approval dates;
- (e) the procedure for requesting interpretations of technical requirements of the standard;
- (f) the following statement: “Suggestions for the improvement of this Standard are welcome. They should be addressed to The American Society of Mechanical Engineers, Secretary, \_\_\_\_\_ Main Committee, Three Park Avenue, New York, NY 10016-5990.”

See Example 3.

## Contents

The amount of detail provided in the table of contents usually varies with the length of the code or standard. In short standards, a list of the main paragraph designations is sufficient; in longer, more complicated documents, a thorough listing of all designated paragraphs may be desired. The purpose of the table of contents is to give the reader a quick overview of the standard. See Example 5.

## Main Text

(a) *Chapters/Sections/Subsections.* Most standards consist of one main chapter; however, for large codes and standards, the main text may be divided into chapters. Within each chapter, the text is divided into two or more major sections (i.e., first level headings; e.g., 1, 2, 3, 4, and 5); each of these may be further divided into two or more subsections. Subsections (i.e., second level headings) are designated by adding a period and number to the section number (e.g., 5.1 and 5.2). A subsection, in turn, may be divided by two or more third level headings, which are designated by adding a second period and another number (e.g., 5.1.1 and 5.1.2). Fourth level headings consisting of four numbers divided by three periods (e.g., 5.1.1.1 and 5.1.1.2) are considered more than adequate to support the material in a document. Any unit of text introducing a new idea or subject should be numbered. All headings should follow hierarchical sequence. For example, a second level heading should be preceded by a first level heading. See Example 6.

(b) *Paragraphs/Subparagraphs/Breakdowns.* For any unit of the text to qualify as a section or subsection and be designated as described in (a) above, it should be titled. Two or more untitled paragraphs may be labeled (a), (b), (c), etc., and further subdivided into (1), (2), (3), etc., if necessary. Subdivision beyond this point results in cumbersome cross-references and should be avoided. *See* Example 6.

(c) *Footnotes.* No material that is part of a standard should be placed in a footnote. Footnotes are added only for the purposes of citation, clarification, illustration, or bibliographic information. In standards, footnotes are numbered consecutively, beginning with page one, and not including the appendices, in which they are numbered independently. If the same footnote is cited frequently throughout the text, the number of the first referenced footnote may be retained for convenience. In codes (and standards with multiple chapters) where extensive footnoting may be desired, footnotes may be numbered consecutively beginning with superscript one for each new chapter, part, or division. All footnotes must be referenced in the text. *See* Example 6.

(d) *Notes.* Notes appear within the text rather than as a footnote. They are part of the standard and are separated from the paragraph to convey emphasis. Notes are numbered if more than one is used in any single location. *See* Example 6.

## Tables/In-Text Tables

(a) *Tables (See Example 7).* Tables provide a clear and concise way of presenting large amounts of data (numerical and/or textual) in a small space. Tables shall be numbered and given titles. They shall be referenced (preferably sequentially) in the text. For simple standards with only one main chapter, tables should be numbered consecutively (e.g., Table 1, Table 2, Table 3). For codes and standards with many chapters or parts, the table will take the designator of the paragraph in which it is first referenced with a suffix -1, -2, -3, etc., to indicate order of reference from a single paragraph. For example, if the paragraph in which a table is referenced is designated as 2.1, the table should be designated as Table 2.1-1. The main components of a table are as follows:

- (1) table designator and title
- (2) column heads
- (3) entries (body)

(4) *Notes.* Notes are sometimes added to tables to further clarify data. When a note applies to the entire table, it is called a General Note and if there is more than one General Note, lettered (a), (b), (c), etc. When a note applies to a specific part of the table, it is referenced within the table and called a Note, numbered

(1), (2), (3), etc., from left to right and top to bottom. Notes are always numbered, even if there is only one in a table.

(b) *In-Text Tables*. Informal tables are used to organize simple tabulations that can be set to fit in the width of a single column. While no table number and title are needed, column heads should be included. *See Example 8.*

## Art

Drawings, charts, and graphs should be prepared in accordance with the latest applicable versions of the ASME Y14 and Y32 standards on abbreviations, drafting, and graphic symbols. The preparers/writers of documents should supply detailed sketches to ASME; ASME will provide the final drawings. Figures shall be numbered, titled, and referenced (preferably sequentially) in the text. The numbering scheme for figures is the same as for tables. General Notes and Notes may also be used in figures. *See Example 9.*

## Equations

Mathematical expressions should be prepared using the latest applicable versions of the ASME Y14 and Y32 standards on drafting and graphic symbols. Formulas of any length or complexity should be set off from the text and centered. However, a very simple expression that can be understood as part of a sentence, such as  $SCFM - 2T_1$ , may remain in the text. Symbols used as variables are printed in italics. All variables should be defined and used consistently wherever they appear (equations, tables, figures, and text). Equations may be numbered consecutively throughout the standard. *See Example 10.*

## Appendices

Appendices contain supplementary information and are placed after the main text for convenience. Ideally, requirements that are part of a standard should be contained in the main body of the standard; however, in books where revisions are made on a regular basis, addition of supplemental requirements in the form of an appendix may become necessary. There are two kinds of appendices: mandatory and nonmandatory. All appendices shall be identified as mandatory or nonmandatory. Preparers/writers of documents should indicate whether an appendix is mandatory or nonmandatory.

(a) *Mandatory Appendices*. A mandatory appendix is a part of the standard that the author was unable to work into the text. Mandatory appendices follow the same designation system used for the main text, preceded by a Roman numeral (e.g., I1.2, Table I1, Fig. I2, IV1, IV2). *See Example 11.*

(b) *Nonmandatory Appendices.* A nonmandatory appendix is not a part of the standard and is added to a standard only for purposes of clarification, illustration, example, and general information. Nonmandatory appendices follow the same designation system used for the main text, preceded by a capital letter (e.g., Table A1, Fig. A2, C1, C1.1, C1.2). **No material that is part of the standard shall be included in a nonmandatory appendix.** See Example 12. (Historical information may be presented in the Foreword; see page 15.)

## Index

The Index is an optional element of a standard and its inclusion should be considered only for very long and complicated documents, where the table of contents is not adequate to aid the reader in locating a subject. The preparers/writers of documents should be aware that any revision to the text may necessitate corresponding revisions to Index entries and that the preparers/writers of documents are responsible for keeping the Index up to date. See Example 13.

This page intentionally left blank.

SPECIAL  
POLICIES

This page intentionally left blank.

# SPECIAL POLICIES

Policies affecting the writing of ASME codes and standards are summarized below and are derived from the ASME Manual for Codes and Standards Development, the ASME Codes and Standards Policies document (CSP), and the policy adopted by the ASME Board on Metrication. These documents are available from ASME Codes and Standards staff.

## COPYRIGHT PAGE

The copyright page is provided by the ASME publishing staff. It contains the date of issuance and year of publication of the code or standard, a description of the addenda and interpretation services provided (see below), and various copyright statements [*see* CSP-9(f) and CSP-33(b)(3)]. Any applicable stamps registered as ASME code or standard symbols are graphically represented on the copyright page. *See* Example 2.

## FOREWORD

Unless otherwise established by the cognizant supervisory board, every Safety Code or Standard shall have a statement included in its Foreword regarding the effective dates for use of an edition and its addenda. *See* CSP-9(c)(2).

## ADDENDA SERVICE

With the issuance of each new edition, the decision should be made whether there is a need to issue periodic revisions, additions, or corrections to the technical requirements by means of an addenda subscription service (*see* CSP-35). Frequency of addenda publication and the scheduled year of issuance of the next new edition should also be determined.

## INTERPRETATIONS

With the issuance of each new edition, the decision should be made whether there is a need to interpret the technical requirements of the code or standard. If this service is provided, a description of the procedure for requesting interpretations should be included in the Foreword, optional Committee Correspondence page

(see Example 4), or Introduction. A description of the service shall appear on the copyright page.

## **RATIONALE**

The rationale for the requirements of a consensus code or standard should never be included as part of the document. The fact that the code or standard was generated through consensus and public approval suffices as the rationale. However, if the committee finds it necessary, a rationale may be printed in the Foreword or a nonmandatory appendix, provided the rationale is subject to the complete approval procedures. See CSP-9(g).

## **USE OF COPYRIGHTED MATERIAL**

If in developing a code or standard, a committee proposes to incorporate material from the copyrighted publication of another organization, it should request written permission from the publisher to reprint the material. If doubt exists as to whether material to be incorporated bears a copyright, permission for use should still be requested from the source organization.

## **COMMERCIAL EQUIPMENT**

References to commercial equipment should be generic and should not include trademarks or other proprietary designations. Where a sole source exists for essential equipment or materials, it is permissible to supply the name and address of the source in a footnote. If it is necessary to refer to a particular model number, the words “or the equivalent” should be added to the reference. See the American National Standards Institute’s (ANSI) commercial terms and conditions policy in “Procedures for the Development and Coordination of American National Standards,” paragraph 1.2.10. This document may be requested from ANSI, which is an independent organization, or found on their web site (<http://www.ansi.org>).

## **REFERENCE TO PATENTED ITEMS**

The practice of developing a code or standard that calls for the use of a patented item should be avoided; however, such a code or standard is not prohibited. ASME should be consulted for guidelines if patented items are to be covered. See the ANSI patent policy in “Procedures for the Development and Coordination of American National Standards,” paragraph 1.2.11.

## SYSTEM OF MEASUREMENT

In 1999, the Board on Metrication of the ASME Council on Codes and Standards reaffirmed the following policy: “All units in works, papers, and periodicals published by the Society shall conform to SI. Customary units may be included. The Council on Codes and Standards shall assure that codes and standards are published in SI units as determined by industry, government, and public needs.”

When a dual-unit code or standard containing both U.S. Customary and SI units is desired, either (a) or (b) below may be followed.

(a) In text, tables, and figures, the SI value may be followed by a U.S. Customary value in parentheses. Parenthetical values, however, should be omitted from mathematical equations and parallel equations should be provided.

(b) Factors for converting U.S. Customary values to SI and vice versa may be included as an appendix. In tables and figures, the conversion factors may be provided in a General Note.

This page intentionally left blank.

# EXAMPLES

This page intentionally left blank.

---

**EXAMPLE 1 Title Page**



The American Society of  
Mechanical Engineers

A N A M E R I C A N N A T I O N A L S T A N D A R D

---

# FORGED FITTINGS, SOCKET-WELDING AND THREADED

**ASME B16.11-1996**  
(Revision of ASME B16.11-1991)

**EXAMPLE 2 Copyright Page**

**A** → Date of Issuance: January 3, 2000

**B** → The 1999 edition of this Standard is being issued with an automatic addenda subscription service. The use of an addenda allows revisions made in response to public review comments or committee actions to be published as necessary. The next edition of this Standard is scheduled for publication in 2004.

ASME issues written replies to inquiries concerning interpretations of technical aspects of this Standard. The interpretations will be included with the above addenda service. **C** →

**D** →  The RTP Stamp is registered in the U.S. Patent Office.

**E** → ASME is the registered trademark of The American Society of Mechanical Engineers.

This code or standard was developed under procedures accredited as meeting the criteria for American National Standards. The Standards Committee that approved the code or standard was balanced to assure that individuals from competent and concerned interests have had an opportunity to participate. The proposed code or standard was made available for public review and comment that provides an opportunity for additional public input from industry, academia, regulatory agencies, and the public-at-large.

ASME does not “approve,” “rate,” or “endorse” any item, construction, proprietary device, or activity. **F** →

ASME does not take any position with respect to the validity of any patent rights asserted in connection with any items mentioned in this document, and does not undertake to insure anyone utilizing a standard against liability for infringement of any applicable letters patent, nor assume any such liability. Users of a code or standard are expressly advised that determination of the validity of any such patent rights, and the risk of infringement of such rights, is entirely their own responsibility.

Participation by federal agency representative(s) or person(s) affiliated with industry is not to be interpreted as government or industry endorsement of this code or standard.

ASME accepts responsibility for only those interpretations of this document issued in accordance with the established ASME procedures and policies, which precludes the issuance of interpretations by individuals.

**G** → No part of this document may be reproduced in any form, in an electronic retrieval system or otherwise, without the prior written permission of the publisher.

The American Society of Mechanical Engineers  
Three Park Avenue, New York, NY 10016-5990 **H** →

**I** → Copyright © 2000 by  
THE AMERICAN SOCIETY OF MECHANICAL ENGINEERS  
All Rights Reserved  
Printed in U.S.A.

- |                                       |                                  |                          |
|---------------------------------------|----------------------------------|--------------------------|
| A Date of issuance                    | D Stamp                          | G Reproduction statement |
| B Addenda service                     | E Registered trademark statement | H Address                |
| C Interpretations service description | F Policy information             | I Copyright              |

---

**EXAMPLE 3 Foreword**

## **FOREWORD**

Agricultural replacement roller chains were introduced around 1956. They were produced to satisfy the requirement for implement engineers who wanted to upgrade from cast or steel detachable to a chain with more strength and durability and still use the same sprockets.

The chains were made available in both drive series (A550 and A620) and conveyor series (CA550 and CA620). They have replaced #55 and 62 detachable chains in many applications and have found use in light duty industrial conveyors.

The Standard establishes essentially only those dimensions that will provide for interchangeability of the chains in use without restricting the chain manufacturers in their overall designs.

The Committee agrees that the CA620 and CA550 chains may be used on #62 and 55 detachable chain sprockets, respectively; however, the sprocket data included in this Standard is for sprockets designed specifically for CA620 and CA550 chains. The difference in sprocket design is necessary because of the difference in roller diameters.

The 1993 revision included updating to current ANSI standards format and symbols covering chains and sprockets. Minimum ultimate tensile strength was redefined. The American National Standards Institute approved ASME B29.19-1993 on October 29, 1993.

This 1996 revision changes the name of the Standard from “A and CA550 and 620 Roller Chains, Attachments, and Sprockets” to “Agricultural Roller Chains, Attachments, and Sprockets.” Also, two new chains (A and CA555 and 557) and several associated attachments are added to the Standard.

Suggestions for the improvement of this Standard are welcome. They should be addressed to The American Society of Mechanical Engineers, Attn: Secretary, B29 Main Committee, Three Park Avenue, New York, NY 10016-5990.

This Standard was approved as an American National Standard on December 9, 1996.

---

**EXAMPLE 4 Committee Correspondence**

**CORRESPONDENCE WITH THE B18 COMMITTEE**

*General.* ASME Standards are developed and maintained with the intent to represent the consensus of concerned interests. As such, users of this Standard may interact with the Committee by requesting interpretations, proposing revisions, and attending Committee meetings. Correspondence should be addressed to:

Secretary, B18 Main Committee  
 The American Society of Mechanical Engineers  
 Three Park Avenue  
 New York, NY 10016-5990

*Proposing Revisions.* Revisions are made periodically to the Standard to incorporate changes that appear necessary or desirable, as demonstrated by the experience gained from the application of the Standard. Approved revisions will be published periodically.

The Committee welcomes proposals for revisions to this Standard. Such proposals should be as specific as possible, citing the paragraph number(s), the proposed wording, and a detailed description of the reasons for the proposal, including any pertinent documentation.

*Interpretations.* Upon request, the B18 Committee will render an interpretation of any requirement of the Standard. Interpretations can only be rendered in response to a written request sent to the Secretary of the B18 Main Committee.

The request for interpretation should be clear and unambiguous. It is further recommended that the inquirer submit his/her request in the following format:

- Subject: Cite the applicable paragraph number(s) and the topic of the inquiry.
- Edition: Cite the applicable edition of the Standard for which the interpretation is being requested.
- Question: Phrase the question as a request for an interpretation of a specific requirement suitable for general understanding and use, not as a request for an approval of a proprietary design or situation. The inquirer may also include any plans or drawings that are necessary to explain the question; however, they should not contain proprietary names or information.

Requests that are not in this format will be rewritten in this format by the Committee prior to being answered, which may inadvertently change the intent of the original request.

ASME procedures provide for reconsideration of any interpretation when or if additional information that might affect an interpretation is available. Further, persons aggrieved by an interpretation may appeal to the cognizant ASME Committee or Subcommittee. ASME does not “approve,” “certify,” “rate,” or “endorse” any item, construction, proprietary device, or activity.

*Attending Committee Meetings.* The B18 Main Committee regularly holds meetings, which are open to the public. Persons wishing to attend any meeting should contact the Secretary of the B18 Main Committee.

**EXAMPLE 5 Contents**

**CONTENTS**

Foreword .....	iii
Committee Roster .....	vii
Correspondence With the B18 Committee .....	ix
<b>1 Introductory Notes .....</b>	<b>1</b>
1.1 Scope .....	1
1.2 Comparison With ISO .....	1
1.3 Types .....	1
1.4 Dimensions .....	1
1.5 Responsibility for Modifications .....	1
1.6 Terminology .....	1
<b>2 General Data for Helical Spring Lock Washers .....</b>	<b>2</b>
2.1 Application .....	2
2.2 Dimensions .....	2
2.3 Material and Hardness .....	2
2.4 Designation .....	3
2.5 Washer Section .....	4
2.6 Coiling .....	5
<b>3 General Data for Tooth Lock Washers .....</b>	<b>5</b>
3.1 Application .....	5
3.2 Tooth Design .....	5
3.3 Dimensions .....	6
3.4 Material and Hardness .....	6
3.5 Designation .....	6
3.6 Manufacturing Detail .....	6
<b>Figures</b>	
1 Verifying Minimum Bearing Width .....	5
2 Washer Twist Test .....	5
<b>Tables</b>	
1 Decarburization Limits .....	2
2 Dimensions of Regular Metric Helical Spring Lock Washers .....	3
3 Dimensions of Heavy Metric Helical Spring Lock Washers .....	4
4 Dimensions of Internal Tooth Lock Washers .....	7
5 Dimensions of Heavy Internal Tooth Lock Washers .....	8
6 Dimensions of External Tooth Lock Washers .....	9

**EXAMPLE 6 Main Text**

**SAFETY STANDARD FOR PLATFORM LIFTS AND STAIRWAY CHAIRLIFTS**

**1 SCOPE**

(a) *Equipment Covered by This Standard.* This Safety Standard covers the design, construction, installation, operation, inspection, testing, maintenance, and repair of inclined stairway chairlifts and inclined and vertical platform lifts intended for transportation of a mobility impaired person only. The device shall have a limited vertical travel, operating speed, and platform area. Operation shall be under continuous control of the user/ attendant.

(b) *Equipment Not Covered by This Standard.* Equipment not covered by this Standard includes, but is not limited to, the following:

(1) elevators, escalators, moving walkways, material lifts, and dumbwaiters within the scope of ASME A17.1b-1997 and later edition;

(2) personnel hoists within the scope of ANSI A10.4;

(3) manlifts within the scope of ASME A90.1.

(c) *Application.* This Standard applies to new installations only.

**2 DEFINITIONS**

This section defines various terms used in this Standard.

*alteration:* any change to equipment other than maintenance, repair, or replacement.

*approved:* acceptable to the *authority having jurisdiction.*

**3 REFERENCES**

The following is a list of publications referenced in this Standard.

ASTM A 307-84a, Specification for Carbon Steel Externally and Internally Threaded Standard Fasteners  
 ASTM A 502-83a, Specification for Steel Structural Rivets

Publisher: American Society for Testing and Materials, 100 Barr Harbor Drive, West Conshohocken, PA 19428-2959

CAN/CSA-B44.1/ASME A17.5, Standard for Elevator and Escalator Electrical Equipment

Publisher: The American Society of Mechanical Engineers (ASME International), Three Park Avenue, New York, NY 10016-5990

**4 INCLINED PLATFORM LIFTS<sup>1</sup>**

Section 4 applies to inclined platform lifts installed in locations other than in or at a private residence for use by the mobility impaired.

**4.1 Runways**

**4.1.1 Means of Egress.** Lifts shall be installed so that the means of egress is maintained as required by the authority having jurisdiction.

**4.1.2 Clearances.** Clearances between the platform and adjacent surfaces shall not be less than 3/4 in. (19 mm). At no point in its travel shall the edge of the platform floor facing the uppermost landing be more than 24 in. (610 mm) above a step or landing as measured vertically.

**4.1.2.1** Headroom clearance where the platform is positioned for boarding shall not be less than 80 in. (2,032 mm) as measured vertically from all points on the surface of the platform floor.

**4.1.2.2** Headroom clearance during travel shall be not less than 60 in. (1 524 mm) as measured vertically from any point on the surface of the platform floor.

**4.1.3 Pipes in Runway Vicinity.** Pipes conveying steam, gas, or liquid which, if discharged into the runway, would endanger life or health shall not be permitted.

NOTE: See Appendix D, Fig. D3 for illustration.

- A Title
- B 1st level heading
- C 1st level breakdown
- D 2nd level breakdown
- E Term/Definition
- F Reference

- G Footnote reference
- H 2nd level heading
- I 3rd level heading
- J 4th level heading
- K Note
- L Footnote

**EXAMPLE 7 Tables**

**TABLE 1 ANVIL AND SPACER DIMENSIONS**

Point Size		Anvil Cone Diameter, A (See Fig. 3)		Spacer Thickness, B (See Fig. 4)	
		+0.000 in. (+0.00 mm) +0.001 in. (+0.03 mm)		±0.0020 in. (±0.051 mm)	
Phillips	Pozidriv	Phillips, in. (mm)	Pozidriv, in. (mm)	Phillips, in. (mm)	Pozidriv, in. (mm)
P0	PZ0	0.033 (0.84)	0.036 (0.91)	0.2520 (6.401)	0.2890 (7.341)
P1	PZ1	0.051 (1.30)	0.055 (1.40)	0.2200 (5.588)	0.2600 (6.604)
P2	PZ2	0.091 (2.31)	0.096 (2.44)	0.1575 (4.001)	0.2200 (5.588)
P3	PZ3	0.151 (3.84)	0.156 (3.96)	0.0638 (1.621)	0.1900 (4.826)
P4	PZ4	0.201 (5.11)	0.204 (5.18)	NA	0.1357 (3.447)

**TABLE 6 DIMENSIONS OF CLASS 125  
CAPS, REDUCING COUPLINGS, AND CLOSED- AND OPEN-PATTERN RETURN BENDS**

Nominal Pipe Size	Length of Thread [Note (1)]		Width of Band, Min., E	Inside Diameter of Fitting, F [Note (1)]		Metal Thick- ness, G	Outside Diameter of Band, Min., H	Length of Reducing Concentric Couplings, M [Note (2)]	Height, Min., P [Note (1)]	Center-to- Center	
	B, Min.	L <sub>2</sub> , Min.		Min.	Max.					Closed, X	Open, Z
1/2	0.43	...	0.50	0.84	0.90	0.13	1.34	1.38	...	1.25	1.75
3/4	0.50	...	0.56	1.05	1.11	0.15	1.63	1.50	...	1.50	1.88
1	0.58	...	0.62	1.31	1.38	0.17	1.95	1.70	...	1.75	2.50
1 1/4	0.67	...	0.69	1.66	1.73	0.18	2.39	2.13	...	2.25	3.00
1 1/2	0.70	...	0.75	1.90	1.97	0.20	2.68	2.25	...	2.50	3.50
2	0.75	...	0.84	2.37	2.44	0.22	3.28	2.32	...	3.25	4.50
2 1/2	0.92	1.14	0.94	2.87	2.97	0.24	3.86	2.63	1.81	3.75	5.50
3	0.98	1.20	1.00	3.50	3.60	0.26	4.62	2.88	1.91	4.50	6.50
3 1/2	1.03	1.25	1.06	4.00	4.10	0.28	5.20	3.13	2.03	...	...
4	1.08	1.30	1.12	4.50	4.60	0.31	5.79	3.38	2.22	6.00	7.50
5	1.18	1.41	1.18	5.56	5.66	0.38	7.05	3.57	2.38	...	...
6	1.28	1.51	1.28	6.62	6.72	0.43	8.28	3.81	2.63	...	...
8	1.47	1.71	1.47	8.62	8.72	0.55	10.63	5.25	2.88	...	...
10	1.68	1.92	1.68	10.75	10.85	0.69	13.12	...	3.50	...	...
12	1.88	2.12	1.88	12.75	12.85	0.80	15.47	...	3.88	...	...

**GENERAL NOTES:**

- (a) Dimensions are in inches.
- (b) Caps may be made flat or with a radius as shown in the illustrations.

**NOTES:**

- (1) Caps may be made without recess. Caps so made shall be of such height P that the length of perfect thread shall be not less than B, and the length of useful thread (B plus threads with fully formed roots and flat crests) shall be not less than L (effective length of external thread) required by ASME B1.20.1, Pipe Threads, General Purpose (Inch).
- (2) Dimension M for all reduction of reducing couplings (concentric only) shall be the same as shown for the largest opening. Dimension M for eccentric couplings is not standard and such information should be obtained from the manufacturer.

A Table title

B Column head

C Data

D Table notes

**EXAMPLE 8 In-Text Table**

Flange thickness at any point within the spot face area, as defined in MSS SP-9, shall not exceed the required minimum thickness by more than the following amounts.

	Nominal Pipe Size	Excess Thickness, Max., in.
	2 to 12	0.12
	14 to 24	0.18
	30 to 96	0.25

When required, all spot facing shall be done in accordance with MSS SP-9. Sharp corners shall be avoided in back facing.

A Column head

B Data

**EXAMPLE 9 Art**

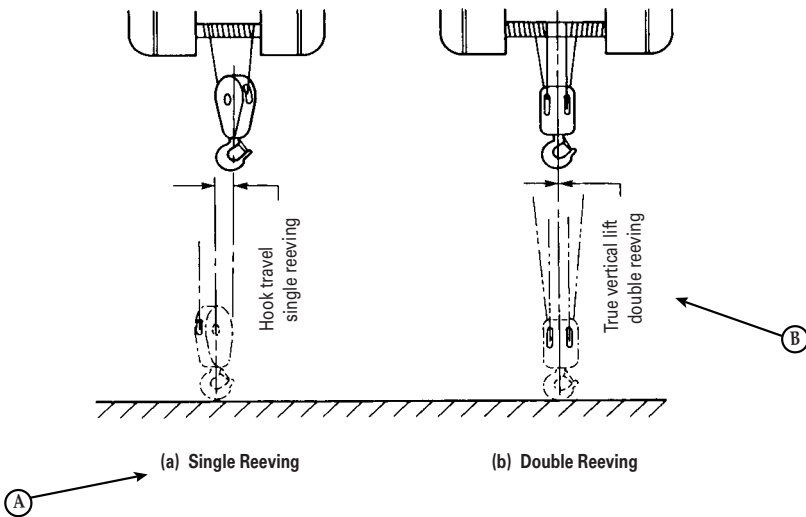

**FIG. 2 SINGLE AND DOUBLE REEVING**

**EXAMPLE 9 Art (Cont'd)**

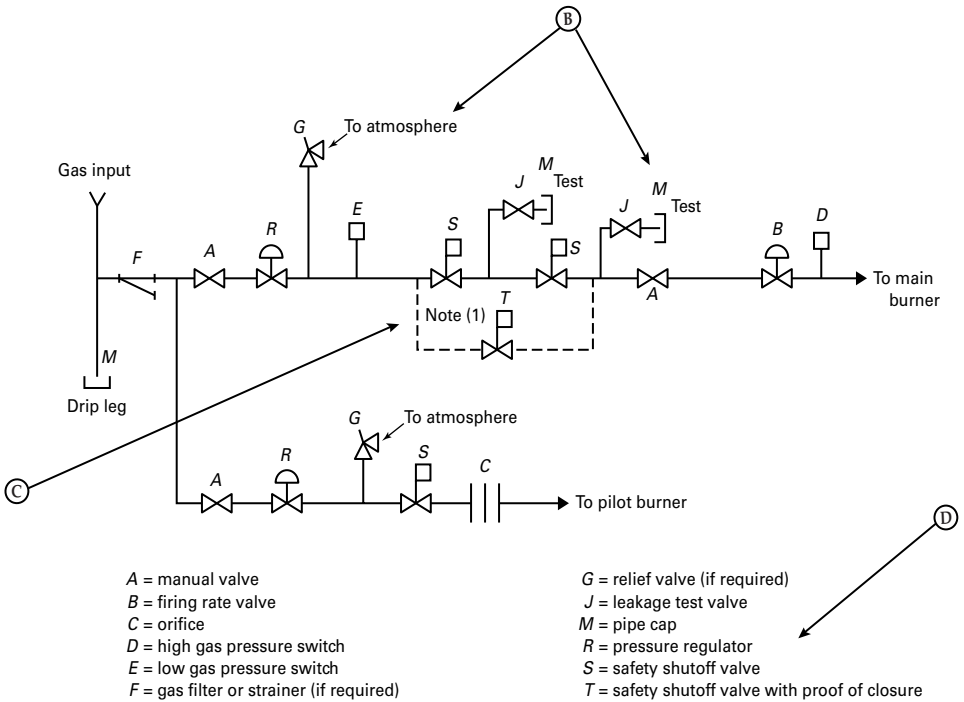

**GENERAL NOTE:** Since boiler design may vary, American National Standard for Gas-Fired Low-Pressure Steam and Hot-Water Boilers, ANSI Z21.13, does not contain a typical fuel train; however, through laboratory testing procedures, ANSI Z21.13 does determine that safe lighting of the boiler will be accomplished; this Standard illustrates a typical fuel train for boilers. The specific fuel train diagram for boilers complying with ANSI Z21.13 is supplied in the boiler manufacturer's instructions.

**NOTE:**

(1) Alternate arrangement – T may be used in place of two S type valves.

**FIG. 3 TYPICAL GAS FUEL TRAIN [GREATER THAN 2,500,000 Btu/hr (732,678 W) AND LESS THAN OR EQUAL TO 5,000,000 Btu/hr (1,465,356 W)]**

- A Sketch title
- B Symbols/Data
- C Note reference
- D Legend
- E Figure notes
- F Figure caption

---

**EXAMPLE 10 Equations**

$$U_t = \frac{0.017 \mu\text{m}}{\sqrt{3}} = 0.01 \mu\text{m} \quad (1)$$

$$S = \frac{P}{h} \sqrt{\left(\frac{\Delta p R^*}{t} + \frac{W}{\pi t R^*}\right)^2 + (\bar{\sigma}_r)^2} \quad (2)$$

$$S = \frac{1}{2} \frac{P}{h} \left[ \sqrt{\left(\frac{\Delta p R^*}{t} + \frac{W}{\pi t R^*}\right)^2 + (\bar{\sigma}_r)^2} + \bar{\sigma}_r + \frac{2p_i h}{P} \right] \quad (3)$$

---

**EXAMPLE 11 Mandatory Appendix**

**MANDATORY APPENDIX IV  
PROTRUSION GAGING OF FLAT AND OVAL COUNTERSUNK HEADS**

**IV1 FLAT COUNTERSUNK HEADS**

Suitability of flat countersunk head screws for application in countersinks designed to the principal dimensions of the screws may be determined by use of a protrusion gage as illustrated in Fig. I1.

The gaging dimensions and the gage diameters are specified in the dimensional tables for flat countersunk head screws. The protrusion limits shown in the tables shall apply only when the gaging diameter is exactly as indicated with the gaging edge of a sharpness obtained by lapping the hole and the top surface of the gage.

**IV2 OVAL COUNTERSUNK HEADS**

Suitability of oval countersunk head screws for application in countersinks designed to the principal dimensions of the screws may be determined by use of a protrusion gage as illustrated in Fig. I2.

The gaging dimensions and the gage diameters are specified in the dimensional tables for oval countersunk head screws. The protrusion limits shown in the tables shall apply only when the gaging diameter is exactly as indicated with the gaging edge of a sharpness obtained by lapping the hole and the top surface of the gage.

---

**EXAMPLE 12 Nonmandatory Appendix**

**NONMANDATORY APPENDIX C  
SEISMIC VIBRATION VERIFICATION TESTS**

**C1 SCOPE**

The purpose of this Appendix is to recommend vibration measurement instrumentation and procedures for measuring vibration at machine installation sites. Vibration levels shall be measured at the proposed machine site(s) to compare to allowable site vibration limits established by the machine supplier.

**C2 VIBRATION ACCEPTANCE CRITERIA**

The machine supplier is to provide site vibration criteria of acceptability. Below these levels the machine can operate successfully, and above these levels problems may occur. Each machine supplier has different

formats and levels of acceptance. The type of vibration measurements to be taken will depend on format and vibration units specified by the machine supplier.

**C2.1 Criteria Units**

Vibration is characterized by amplitude versus time or frequency. The amplitude can be defined in displacement, velocity, acceleration, or power spectral density. Depending on the type of criteria, the amplitude ordinate can be defined in either the time domain or frequency domain.

**C2.1.1 Amplitude Units.** Since the machine is a cutting tool, units of displacement are most useful in relation to machine performance.

**EXAMPLE 13 Index**

**INDEX**

A

Abbreviations, nonmetals, A326.3 (*see also* symbols)  
 Acceptance criteria, Tables 302.3.3C and D, 323.3.5, Table 323.3.5, 341.3.2, Table 341.3.2, 341.3.3, 341.4, 341.5, 344.6.2, A328.2.1, A341.3, Table A341.3.2, A341.4.1, K302.3.3, K323.3.5, Table K323.3.5, K341.3, Table K341.3.2

Acidic materials, effects of, F323.4

Adhesive joints (*see also* solvent cemented)

definition (*see* bonded joint)  
 in metallic piping, M318.2, K318.2  
 in nonmetallic piping, A328.5.6, MA311.2

Air condensation, 301.11

Alignment, 328.4.2, 328.4.3, Fig. 328.4.3, 335.1.1, 341.4.1, 341.4.3, M335.1.1, K328.4.3

Allowable pressures, nonmetals, Tables B-4 and B-5

Allowable stress  
 definition, 300.2  
 values, Table K-1

Allowable stress amplitude, K302.3.1, K304.8.3

Allowable stress bases, 302.3, A302.3, M302.3, K302.3

metallic materials, 302.3.2, M302.3.2, K302.3.2  
 nonmetallic materials, A302.3.2

Allowable stress range, 302.3.5, 319.1, 319.3.4, K302.3.5, K319.1

Allowable stress values for

bolting, Table A-2  
 clad metals, linings, 323.4.3, K323.4.3  
 metals, Tables A-1 and K-1  
 supports, 321.1.3  
 testing, 302.3.6, 345.2.1, A302.3.4, K302.3.6  
 thermoplastics, Table B-1

Allowances

corrosion, erosion, 302.4, 304.1.1, A304.1.1, M302.4, MA302.4, K302.4, K304.1.1  
 for pressure-temperature variations, 302.2.4, A302.2.4, M302.2.4, K302.2.4, App. V  
 grooving, threading, 302.4, K302.4  
 mechanical strength, 302.4.1

Alternating stress, K304.8.2, K304.8.3

Alternative leak test, 345.1, 345.9, K345.1

Aluminum and aluminum alloys

allowable stresses, 319.3.4, Tables A-1 and A-2

effects, F323.4

flanges, specification, App. L

fluid service requirements, 323.4.2

precautions, F323.4

quality factors, Tables A-1A and A-1B

welding, 323.4.2, Notes for App. A

Ambient effects, 301.4, F301.4

Analysis

fatigue (*see* fatigue analysis)

flexibility, 319.4, 321.1.2, A319.4, M319.4, K319 product, K323.1.5

properties for, 319.3, A319.3

support, 321.1.2, K321

Anchors, 319.7, 321.2.1, A319.7

Antimony, effects of, F323.4

A-Numbers, Tables 330.1.1 and 331.1.1

Appendices (*see* Contents)

status of, 300(f), 300.4

Application of Code, Introduction

Assembly, 300.2, 335, A335, M335, K335

Atmospheric icing, 301.4.3

Attachments, 321.1.4, 321.3, K321 (*see also* supports)

Backing filler material (*see* consumable insert)

Backing material, 300.2, 328.3.2, 328.4.2, M311.2, M328.3.2, K311.2.3, K328.3.2, K328.4.2

Base material, def., 300.2

Bases for allowable stresses (*see* allowable stress bases)

Basic allowable stress

definition, 300.2  
 values, Table A-1

Bearing

allowable stress, 302.3.1, K302.3.1  
 test, A302.3.3

Bell type joints (*see also* caulked joints and packed joints)

assembly, 335.5, A335.5

fluid service requirements, 316, 318.1, A318, M318

Bellows expansion joints, 345.3.3, 345.4.2, F304.7.4, K304.7.4, App. X

Bending, 332.2, A332.2, M332, MA332, K332.2

B

C

A Main entry

B Subentry

C Designator

# REFERENCE NOTATIONS

This page intentionally left blank.

# LIST OF SI UNITS

Quantity	Unit	Symbol	Other Units or Limitations
<b>Space and Time</b>			
plane angle	radian	rad	degree (decimalized)
length	meter	m	
area	square meter	m <sup>2</sup>	
volume	cubic meter	m <sup>3</sup>	liter (L) for liquid only (use without prefix other than in milliliter, mL)
time	second	s	minute (min), hour (h), day (d), week, and year
<b>Periodic and Related Phenomena</b>			
frequency	hertz	Hz	revolutions per second (r/s)
rotational frequency	revolutions per second	s <sup>-1</sup>	revolutions per minute (r/m)
<b>Mechanics</b>			
mass	kilogram	kg	
density	kilogram per cubic meter	kg/m <sup>3</sup>	
moment of inertia	kilogram · meter <sup>2</sup>	kg · m <sup>2</sup>	
force	newton	N	
moment of force (torque)	newton-meter	N · m	
pressure and stress	pascal	Pa	(pascal = newton per square meter)
energy, work	joule	J	kilowatt-hour (kW · h)
power	watt	W	
impact strength	joule	J	
section modulus	meter <sup>3</sup>	m <sup>3</sup>	
moment of section (second moment of area)	meter <sup>4</sup>	m <sup>4</sup>	
fracture toughness	Pa · $\sqrt{\text{m}}$		
<b>Heat</b>			
temperature — thermodynamic [Note (1)]	kelvin	K	degree Celsius (°C)
temperature — other than thermodynamic	degree Celsius	°C	kelvin (K)
linear expansion coefficient	meter per meter-kelvin	K <sup>-1</sup>	°C <sup>-1</sup>
quantity of heat	joule	J	
heat flow rate	watt	W	
thermal conductivity	watt per meter-kelvin	W/(m · K)	W/(m · °C)
thermal diffusivity	square meter per second	m <sup>2</sup> /s	
specific heat capacity	joule per kilogram-kelvin	J/(kg · K)	J/(kg · °C)
<b>Electricity and Magnetism</b>			
electric current	ampere	A	
electric potential	volt	V	
current density	ampere per meter <sup>2</sup>	A/m <sup>2</sup>	
magnetic field strength	ampere per meter	A/m	

**GENERAL NOTES:**

(a) Conversion factors between SI units and U.S. customary are given in SI-1, *ASME Orientation and Guide for Use of SI (Metric) Units*, and IEEE/ASTM SI-10.

(b) For additional metric unit abbreviations, see Abbreviations on next page.

**NOTE:**

(1) Preferred use for temperature and temperature interval is degrees Celsius (°C), except for thermodynamic and cryogenic work where kelvins may be more suitable. For temperature interval, 1 K = 1°C exactly.

## ABBREVIATIONS

Word/Phrase	Abbreviation	Word/Phrase	Abbreviation
British thermal unit	Btu	miles per hour	mph
centimeter	cm	millimeter	mm
cubic inch	cu in./in. <sup>3</sup>	minimum	min.
cubic millimeter	mm <sup>3</sup>	minute (angle)	'
degree (angle)	deg	[Note (1)]	
degree (temperature)	°	minute (time)	min
[Note (1)]		nominal pipe size	NPS
diameter	dia	ounce	oz
Fahrenheit	°F	outside diameter	O.D.
foot	ft	plus or minus	±
gallon	gal	pound	lb
gram	g	pound per linear inch	lb/in.
hour	hr	pound per square inch	psi
inch	in.	pound per square inch absolute	psia
inside diameter	I.D.	pound per square inch gauge	psig
kilojoule	kJ	second (angle)	"
kilopascal	kPa	[Note (1)]	
kilovolt	kV	second (time)	sec
kilowatt	kW	square inch	sq in./in. <sup>2</sup>
kips per square inch	ksi	square millimeter	mm <sup>2</sup>
maximum	max.	ton	ton
mega electron volt	MeV		
megapascal	MPa		
megavolt	MV		

**GENERAL NOTES:**

- (a) For additional metric unit abbreviations, see List of SI Units on previous page.
- (b) Plural words/phrases are abbreviated the same way as they are when singular.

**NOTE:**

- (1) Symbols are used in tables and/or art only.

# PROOFREADING/COPYEDITING MARKS

Insertions of punctuation marks, single letters, words, sentences, and/or numerals are always indicated with a caret (^), which is placed at the exact spot in the copy where the correction is to be made. When a letter or character is to be deleted, it is crossed out. See specific instructions for other corrections in the table below. Proofreading marks should be placed in the document margins; multiple marks in the same line should be separated with a slash.

Insertions of more than a few words should be referenced as an attachment. For example, if you want to insert a new paragraph, place a caret at the spot in the text where it should be inserted, put a reference to the attachment in the margin (i.e., Attachment A), and include an attachment containing the new text with your document submission. This method is the only legible way to submit significant text changes and/or additions.

**Example:** This Standard provides safety requirements for the design, construction, testing, and use of ripping chisels <sup>an</sup> flooring/electricians <sup>chisels</sup>. These chisels are intended for use cutting woods <sup>and</sup> light prying <sup>such as</sup> cutting the tongues of installed flooring sections and raising and removing floor planks <sup>^</sup>

tr  
 ~d/ ✓/  
 e/ ✓/  
 ○

Margin Mark	Manuscript Example	Explanation	Margin Mark	Manuscript Example	Explanation
	This <del>standar</del> y	Delete character marked	<i>caps</i>	<u>This standard</u>	Capitals
	This <del>standar</del> rd	Delete and close up		read. <sup>^</sup> The good	Start paragraph
	King <sup>o</sup> Geo.	Spell out	No  and Run in	marked.	No paragraph, run in
<i>tr</i>	A <sup>manuscript</sup> good	Transpose		This standard <sup>used</sup>	Break here; start new line
<i>h</i>	<sup>Te</sup> manuscript	Insert	// align	The engineer	Align type
<i>stet</i>	This <del>standar</del> d	Let it stand		Two members	
	This stan <sup>ard</sup>	Close up, no space		The manuscript <sup>read</sup>	Move right
<i>less #</i>	The <sup>^</sup> manuscript	Less space		The manuscript <sup>^</sup> read	Move left
<i>Eq #</i>	A <sup>^</sup> good <sup>^</sup> manuscript	Equal space	<i>Ed: comma?</i>	the 2000 <sup>^</sup> report	Query for editor
<i>#</i>	This <sup>^</sup> standard	Insert space	<i>Au: 2000, ?</i>	Pages 1 <sup>^</sup> 20	Query to author
<i>bf</i>	This <del>standar</del> d	Boldface	$\frac{1}{N}$	The third <sup>^</sup> and most	Insert en dash
<i>=</i>	ASME HST <sup>^</sup> 6M	Hyphen	$\frac{1}{M}$	difficult — problem ...	Insert em dash
<i>ital</i>	This <u>standard</u>	Italic		Letters <sup>or</sup> words	Move up
<i>rom</i>	This <u>(standard)</u>	Roman		Letters <sup>or</sup> words	Move down
<i>lc</i>	This <del>standar</del> d	Lowercase			
<i>u/lc</i>	<u>MANUSCRIPT</u>	Upper- & lowercase			
<i>caps/ital</i>	<u><u>This standard</u></u>	Caps & italic			

ISBN 0-7918-2630-9



9 790791 826309



CS0000